



**2023**

# **Annual Drinking Water System Report**

A.L. Dafoe (Napanee) Drinking Water System

DWS# 220002226

75 East Street  
Napanee, Ontario

Prepared: January 2024

---

## Executive Summary

The A.L. Dafoe Water Treatment Plant is a conventional design, chemically assisted filtration plant that treats water drawn from Lake Ontario and supplies drinking water to approximately 8500 residents of the town of Napanee. Reliability of the system is supported by continuous monitoring instrumentation, process alarms, and critical equipment redundancy.

During 2023, the volume of treated water provided to the community increased by approximately 14 percent when compared to that produced during 2022. Average day flow measured in 2023 was approximately 56 percent of the plant design capacity of 10,450 m<sup>3</sup>/d, while the maximum day flow amounted to approximately 77 percent of that capacity.

Water samples collected throughout the process are tested for over 80 different parameters to evaluate treatment efficiency and to ensure finished water quality. Target parameters range from critical indicators related to potential acute health effects to non-health related parameters that aid in assessing process performance or the aesthetic quality of the drinking water. All test results from samples collected during 2023 met the stringent requirements of the Ontario Drinking Water Quality Standards.

In addition to ongoing routine preventive maintenance practices, notable improvements during 2023 included:

- Replacement of 186 residential water meters to improve the monitoring of water usage and to aid in reducing water loss.
- Within the distribution system, the watermain on East Street underwent construction which included complete replacement of existing watermain, water services and curb stops.

The Town of Greater Napanee has successfully implemented a quality management system that continues to conform to the requirements of the Ontario Drinking Water Quality Management Standard. Implementation of the system demonstrates the Town's commitment to continual improvement.

---

## Table of Contents

Executive Summary .....	i
Table of Contents.....	ii
List of Figures .....	iv
List of Tables.....	iv
Key Words & Terms.....	v
Introduction .....	7
1 Description of the Treatment Process .....	9
Raw Water Supply.....	9
Pre-chlorination / Zebra Mussel Control .....	9
Coagulation / Flocculation / Sedimentation .....	12
Filtration .....	12
Disinfection (Chlorination) .....	13
Treated Water Storage Tanks and Pressure Booster Stations.....	13
Treatment Chemicals .....	14
Waste Residuals Treatment .....	16
Origins and Types of Contaminants .....	17
Multiple Barriers to Microbiological Pathogens.....	18
Laboratory Testing .....	18
Alarms and Staffing.....	18
2 Reporting of Adverse Water and Other Deficiencies .....	19
3 Flow Measurement and Analytical Testing.....	20
Raw and Treated Water Flow.....	20

---

Turbidity .....	21
Temperature, Colour, pH, and Alkalinity.....	23
Disinfection.....	24
Bacteriological Testing .....	25
Process Chemical Addition .....	28
Chemical Testing .....	29
Lead Testing .....	32
Waste Residuals Treatment Process .....	33
4 System Maintenance and Improvements .....	35

## List of Figures

Figure 1: A.L. Dafoe Water Treatment Plant Raw Water Transmission Schematic .....	11
Figure 2: A.L. Dafoe Water Treatment Plant Process Schematic.....	15
Figure 3: A.L. Dafoe Water Treatment Plant Waste Residuals Treatment Process Schematic .....	17
Figure 4: Monthly average daily treated water flow trends for 2022 and 2023.....	21

## List of Tables

Table 1: Summary of raw and treated water flow for 2023 .....	20
Table 2: Summary of turbidity in raw water and filter effluent for 2023 .....	22
Table 3: Summary of temperature, pH, alkalinity and colour in raw and treated water for 2023 ....	23
Table 4: Summary of treated water disinfection and bacteriological results from 2023.....	26
Table 5: Summary of distribution water disinfection and bacteriological results from 2023 .....	27
Table 6: Summary of raw water disinfection and bacteriological results from 2023.....	27
Table 7: Summary of process chemical usage and dosage for 2023 .....	29
Table 8: Results of samples collected on January 10, 2023 to meet testing for parameters listed in Schedule 23 of O.Reg. 170/03.....	30
Table 9: Results of samples collected on January 10, 2023 and February 07, 2023 to meet testing for parameters listed in Schedule 24 or O.Reg. 170/03.....	30
Table 10: Results of samples collected on January 07, 2020 to meet testing for Fluoride and Sodium in O. Reg. 170/03 .....	31
Table 11: Results of samples to meet requirements under Sched. 15 of O.Reg. 170/03.....	31
Table 12: Results of samples to meet requirements under Sched. 13 of O.Reg. 170/03.....	32
Table 13: Results of samples collected/analyzed to meet requirements under Sched.15.1 of O.Reg. 170/03 .....	33
Table 14: Summary of results from waste residuals treatment process monitoring .....	34

---

## Key Words & Terms

<b>m<sup>3</sup>/d</b>	cubic metres per day (1m <sup>3</sup> = 1000 litres)
<b>mg/L</b>	milligrams per litre, (1 part in 1,000,000)
<b>ug/L</b>	micrograms per litre, (1 part in 1,000,000,000)
<b>ACU</b>	apparent colour units (standard unit to quantify colour in water)
<b>HPC</b>	Heterotrophic Plate Count
<b>NTU</b>	nephelometric turbidity units (standard unit to quantify turbidity in water)
<b>MAC</b>	maximum acceptable concentration
<b>IMAC</b>	interim maximum acceptable concentration
<b>AO</b>	aesthetic objective (non-health related)

**Coagulation / Flocculation** refers to the water treatment chemical processes that convert small particles of suspended solids into larger, more easily settled clumps.

**CT** is the product of chlorine residual concentration and the time the residual remains in the water until the first consumer – effective disinfection requires adequate CT

**Disinfection** refers to the process that kills or inactivates disease-causing organisms in water, usually involving the addition of chlorine.

***Escherichia Coli (E. Coli)*** refers to a subgroup of fecal coliform bacteria that reside in the digestive systems of warm blooded animals. The presence of *E. Coli* in drinking water is a strong indicator of fecal contamination. *E. Coli* is rapidly destroyed by chlorine.

**Filter Underdrain** is located at filter bottom, the under-drain allows the passage of filtered water while retaining filter media

**Flocculation Tank** is a large baffled process tank that gently mixes the process flow to increase the size of floc formed by coagulant

**Heterotrophic Plate Count (HPC)** is a microbial test method that quantifies levels of heterotrophic bacteria. Most bacteria, including many of those common in drinking water systems, are heterotrophs. Within a distribution system, increases in the density of HPC bacteria are usually the result of bacterial re-growth which is influenced by the quality of the water entering the system, temperature, flow conditions (i.e. stagnation), presence of a disinfectant residual, construction materials, and the availability of nutrients for growth. HPC in drinking water are not considered a direct health threat to the general public.

**Inorganic** refers to non-carbon based substances. Common inorganic substances in water include metals, minerals, nutrients, and salts.

**ODWQS** – refers to the Ontario Drinking Water Quality Standards. The ODWQS define the quality standards, objectives, and guidelines to be followed for the protection of public health through the provision of safe and aesthetically acceptable drinking water supply.

**Ontario Regulation 170/03 or O.Reg.170/03** - refers to the Drinking Water Systems Regulation as amended.

**Ontario Regulation 169/03 or O.Reg.169/03** - refers to the ODWQS Regulation as amended.

**Organic** refers to a large group of carbon-based chemical compounds including all animal and vegetable matter plus many synthetic compounds such as pesticides and industrial solvents.

**Raw Water** is defined as surface (lakes, rivers) or ground water (wells) available as a source of drinking water that has not received any treatment.

**Sedimentation** refers to the water treatment process where the velocity of water is reduced in large tanks so that the suspended material can settle by gravity.

**Static Mixer** is a helical shaped pipe insert designed to create an extremely turbulent flow pattern

**Total Coliform Bacteria** are a group of commonly occurring, mostly harmless bacteria that live in soil and water as well as the gut of animals. Their presence in a water sample may be indicative of inadequate filtration and/or inadequate disinfection.

**Turbidity** refers to a physical characteristic of water that causes a cloudy appearance. Turbidity is caused by the presence of suspended matter. The substances that cause turbidity can shield potentially pathogenic organisms from disinfection.

**Waste Equalization Tank** refers to a large holding tank used for temporary storage and mixing of batch waste stream discharges

---

## Introduction

The 2023 Annual Drinking Water Report for the A.L. Dafoe (Napanee) Drinking Water System summarizes plant operations and treated water quality with reference to the requirements of:

- Ontario Regulation 170/03 (O. Reg. 170/03)
- Ontario Regulation 169/03 (O. Reg.169/03)
- Permit to Take Water 6442-9Q7SDA
- Municipal Drinking Water Licence 157-101
- Drinking Water Works Permit 157-201

This report consolidates the reporting requirements specified as “Annual Report” in O.Reg. 170/03, Section 11, and “Summary Report” in O.Reg.170/03, Schedule 22.

Information provided in this report includes the following:

- Section 1 of the report provides a detailed description of the water treatment process
- Section 2 provides a summary of reports to the Ministry under Subsection 17(1) of the Safe Drinking Water Act (notices of adverse water quality) and Schedule 16, Section 16-4 of O. Reg. 170/03 (notice of inadequate disinfection), as well as any corrective actions taken under Schedule 17.
- Section 3 summarizes the analytical data generated from “in house” analysis as well as contracted analyses conducted at an accredited laboratory in accordance with O.Reg.170/03. Raw and treated water flow rates are also discussed in Section 3. Chemicals used in the treatment process are discussed in both Sections 1 and 3 and are summarized in the tables appearing at the end of this report.
- Section 4 contains a summary of significant maintenance and upgrading projects completed during 2023.



Copies of Annual Drinking Water Reports are available to the public, free of charge, from the Administration Office located at 99-A Advance Avenue in Napanee. Reports are also available on-line at: <http://www.greaternapanee.com>. Additional information on drinking water standards in Ontario is available from the Ontario Ministry of the Environment, Conservation and Parks (<https://www.ontario.ca>)

---

# 1 Description of the Treatment Process

## ***Raw Water Supply***

Two pumps located at the Lake Ontario Pumping Station (County Road 21 and Highway 33), referred to as low lift pumps, are used to transfer raw water from Lake Ontario to the A.L. Dafoe Water Treatment Plant. Only one pump operates at any given time, while the second is reserved for backup duty. The low lift pumps draw directly from a screened intake crib (to prevent passage of large debris) located 50 meters offshore. The low lift pumps discharge through approximately 16 km of 500 mm diameter pipeline to the reservoirs located at the corner of Golf Course Lane and County Road 8. In the event of a power interruption, the Lake Ontario Pumping Station is equipped with switching gear that accommodates direct connection to a mobile diesel generator.

Raw water flows by gravity through a 400 mm diameter pipe from the reservoirs to the treatment plant. The flow of raw water from the reservoirs is controlled by the volume of treated water stored at the plant. As water is used by the community, valves open to allow raw water into the process to replenish the treated water reserves.

If circumstances arise that prevent the transfer of raw water from Lake Ontario, the treatment plant inlet valves can be manually adjusted to draw from the Napane River.

## ***Pre-chlorination / Zebra Mussel Control***

The addition of chlorine to the raw water supply is called pre-chlorination, and serves three main purposes:

1. prevent biological growth within the raw water pipeline and reservoirs
2. provide initial disinfection
3. control the growth of Zebra Mussels

The growth of Zebra Mussels (an invasive species in the Great Lakes), if not controlled, can accumulate and eventually plug the raw water intake pipe. Chlorine is added to the raw water through a diffuser located within the raw water intake crib to control growth in the immediate area of the intake pipe. Chlorine pumping is activated only when the low lift pumps are running to avoid excessive

accumulation of chlorine concentration in the aquatic environment surrounding the intake crib. The intake crib was last inspected and cleaned by an underwater inspection contractor in April 2021, and repairs were made to the intake crib in June 2021.

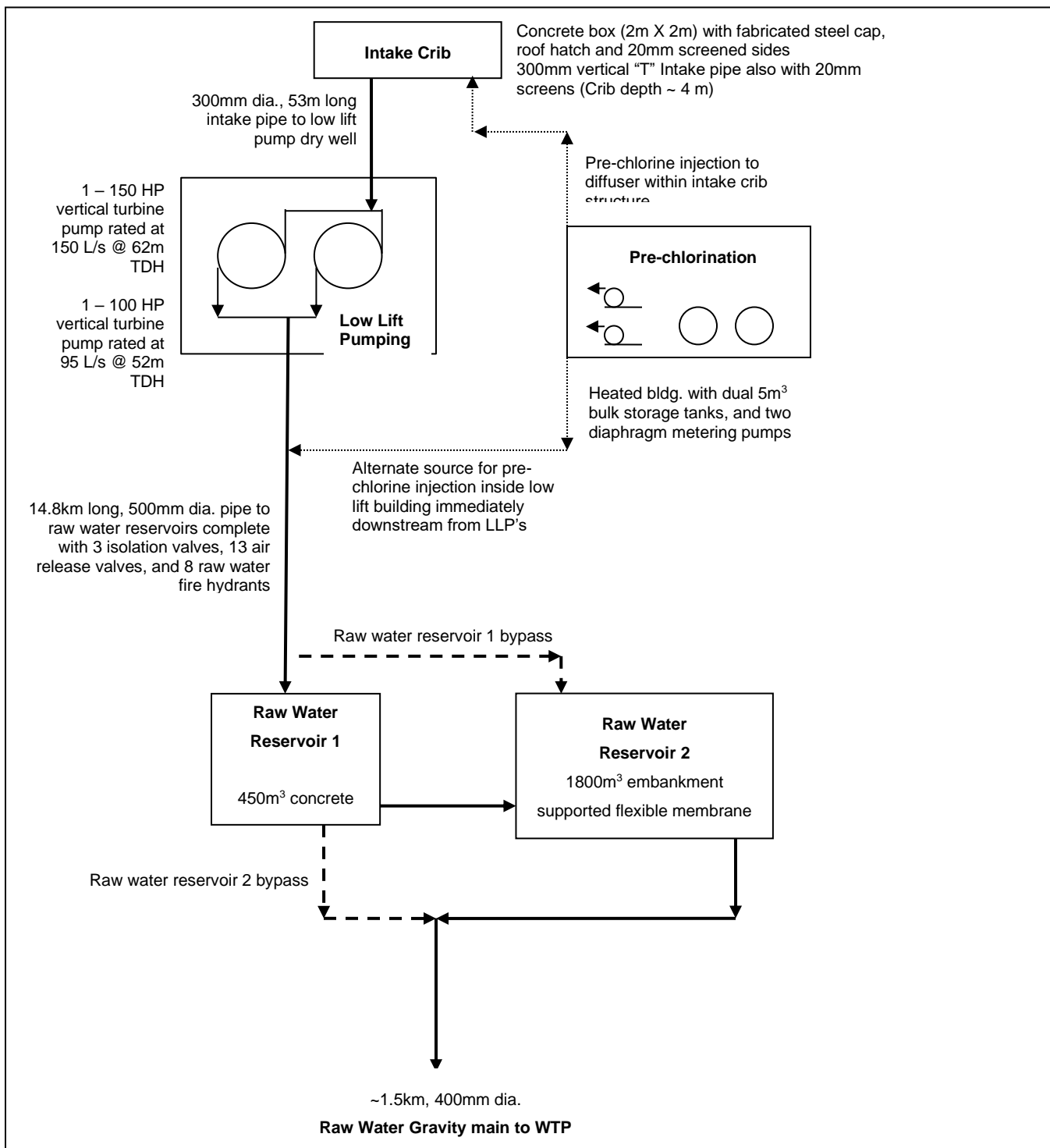

Figure 1: A.L. Dafoe Water Treatment Plant Raw Water Transmission Schematic

---

### **Coagulation / Flocculation / Sedimentation**

Aluminum sulfate (liquid alum), which acts as a coagulant, is added to the incoming raw water upstream from the flocculation tank. The coagulant converts dispersed and colloidal solids suspended in the raw water (measured as turbidity) to small visible clumps. The coagulation reactions occur very rapidly as the alum and process water mix together within a static mixer. As the coagulated process water passes through the baffled flocculation tank, the coagulated clumps collide, forming larger clumps commonly referred to as floc.

Following the flocculation tank, the process water flows into large rectangular sedimentation tanks where velocity is decreased allowing the relatively heavy floc particles to settle by gravity.

Accumulated floc (alum sludge) from the bottom of the sedimentation tanks is discharged to the waste residuals treatment process (described in more detail below). The upper, clear portion of the sedimentation tank flows to the filters for further treatment.

Coagulation, flocculation and sedimentation are treatment processes which together serve as a barrier to the passage of potentially harmful organisms by removing turbidity from the water.

### **Filtration**

Overflow from the sedimentation tanks flows to the top of the filters. Flow moves downward through two parallel dual media filters comprised of a top layer of granular activated carbon (GAC) overlying a lower layer of sand.

The GAC layer adsorbs compounds that cause taste and odour as well as other trace organic compounds sometimes present in the raw water supply. GAC is effective in removing algal toxins such as those produced by blue-green algae.

Filtration, which takes place in the sand layer, physically removes suspended particles, including floc which may carry over from the sedimentation tanks. The filtered water passes through the filter under-drain and into storage reservoirs, commonly referred to as clearwells.

Debris which accumulates on the filter media must be periodically removed by a procedure called backwashing. During backwashing, the filter is isolated from the process and treated water is pumped

---

upward, (reversed from normal filter flow), expanding the media bed and loosening accumulated debris. The backwash water with loosened debris is discharged to the waste residuals treatment process.

### ***Disinfection (Chlorination)***

Chlorine, in the form of liquid sodium hypochlorite, is added to the process in two locations. Raw water is chlorinated to control the growth of Zebra Mussels and to limit biological growth in the raw water pipeline and reservoir.

The second point of chlorine addition, referred to as post-chlorination, occurs immediately upstream from the treated water clearwells. Post-chlorination serves as the final barrier ensuring that potentially harmful organisms do not enter the town distribution system. A sufficient dosage of chlorine is added at the purification plant to achieve the required disinfection CT and to maintain a residual concentration throughout the distribution system. Distribution chlorine residual prevents biological growth within the distribution piping.

### ***Treated Water Storage Tanks and Pressure Booster Stations***

Treated water is pumped from the treated water clearwells into the distribution system. Constant pressure is maintained in the central area of the distribution system by the water column height in the two treated water storage tanks, both integral components of the distribution system. The storage tank is located on County Road 2 and provides 4600 m<sup>3</sup> of treated water storage capacity, while the older elevated storage tower on East Street provides approximately 1100 m<sup>3</sup> of treated water storage capacity for use during periods of high demand and for community fire protection.

The distribution system also includes two pressure booster stations. The booster stations house inline pumps that restore adequate water pressure to areas distant or elevated in relation to the treatment plant or storage tanks. One station is located on McCabe Street to overcome the head-loss caused by the relatively higher elevation at the southern extreme of the distribution system. The second station is located on Community Road and maintains pressure to the industrial area north of Highway 401.

---

### ***Treatment Chemicals***

Two chemicals, sodium hypochlorite and aluminum sulfate, are used in the A. L. Dafoe Water Treatment Plant process.

Sodium hypochlorite is added for pre-chlorination and Zebra Mussel control at the Lake Ontario Pumping Station, and for post-chlorination disinfection at the treatment plant. The sodium hypochlorite solution contains approximately 12 percent chlorine and meets the standards of the Canadian General Standards Board and American Water Works Association (AWWA) B300-18 for use in drinking water.

Aluminum sulfate, also known as liquid alum, serves as a coagulant in the treatment process. (Refer to subsection describing coagulation / sedimentation.) The liquid alum meets all specifications for AWWA B403-16 and the National Sanitation Foundation Standard 60 for potable water use at a maximum dosage of 150 mg/L.

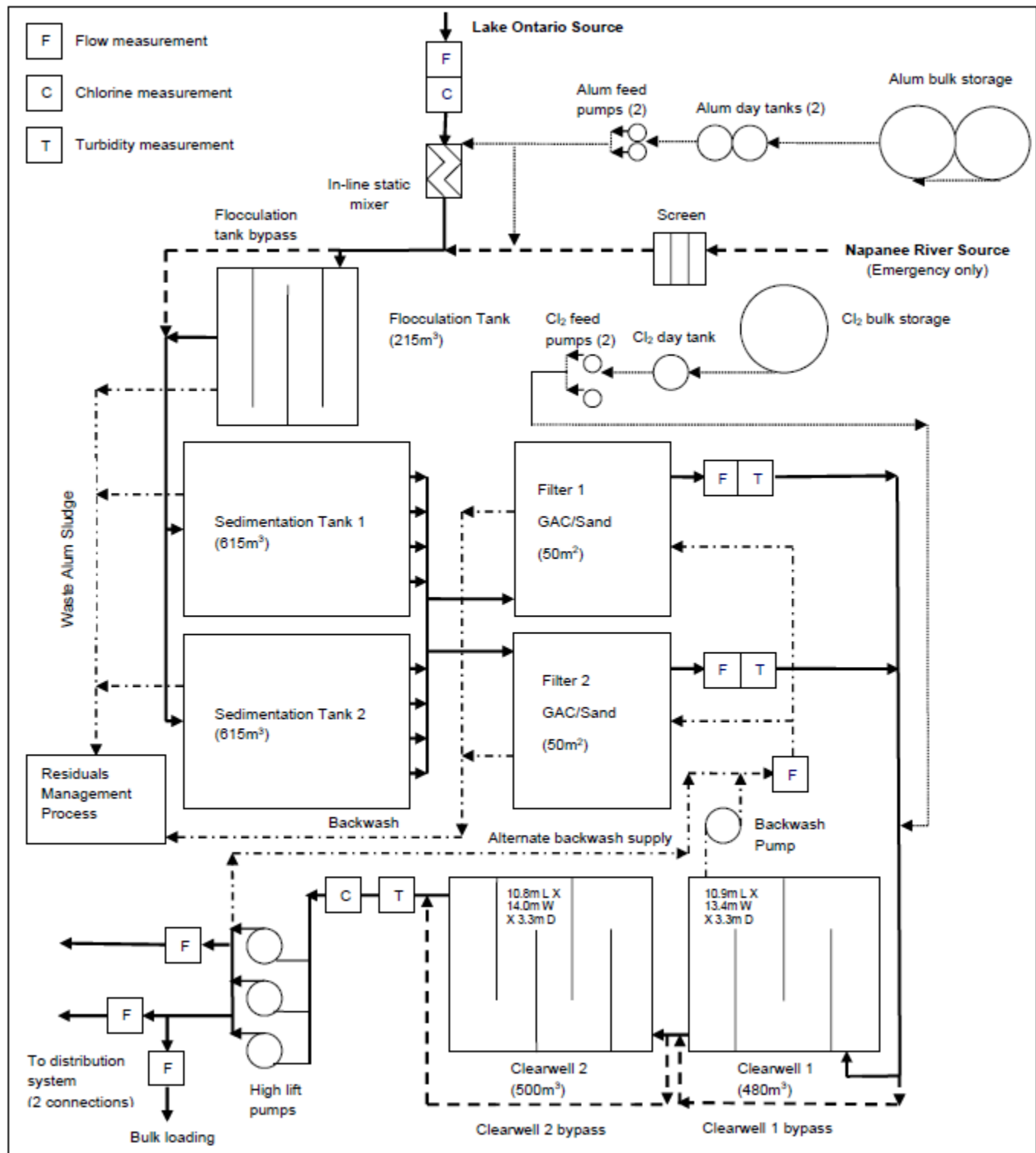

Figure 2: A.L. Dafoe Water Treatment Plant Process Schematic



---

## ***Waste Residuals Treatment***

Waste residuals generated through the treatment process include filter backwash water, sedimentation tank sludge, and other wastes discharged during tank maintenance. Those waste streams are directed to the waste equalization tank. From the equalization tank, the blended waste is pumped to the waste residuals treatment process described below. A process flow diagram is provided on the following page.

The waste stream enters the residuals treatment process into a draft tube. The draft tube is a vertical cylindrical chamber equipped with a rotating turbine. Polymer is added to the process as a coagulant aid to produce sticky floc particles that clump together particulate matter present in the waste. Floc formation is enhanced by the mixing and shearing action of the turbine. The process stream (with floc particles) is drawn upward by the turbine, over the top edge of the draft tube. Flow then moves at a decreased velocity under one baffle and over a second baffle. The gentle mixing created by the baffles causes the relatively small floc particles to gather, (becoming larger and heavier), prior to entering the settling compartment.

The top portion of the settling compartment contains inclined settling tubes designed to maximize the settling velocity of the floc as flow passes through. The floc settles to the bottom of the settling compartment, while the clear liquid at the top of the settling zone is discharged to the Napanee River. Prior to discharge, the liquid is measured for chlorine residual and suspended solids, and if required, it is dechlorinated before it is released to the Napanee River. Recirculation of settled floc from the bottom of the settling compartment back to the draft tube enhances floc formation in the incoming wastewater at the beginning of the process. Excess accumulation of settled floc is pumped to the sanitary sewer for further treatment at the Napanee Water Pollution Control Plant.

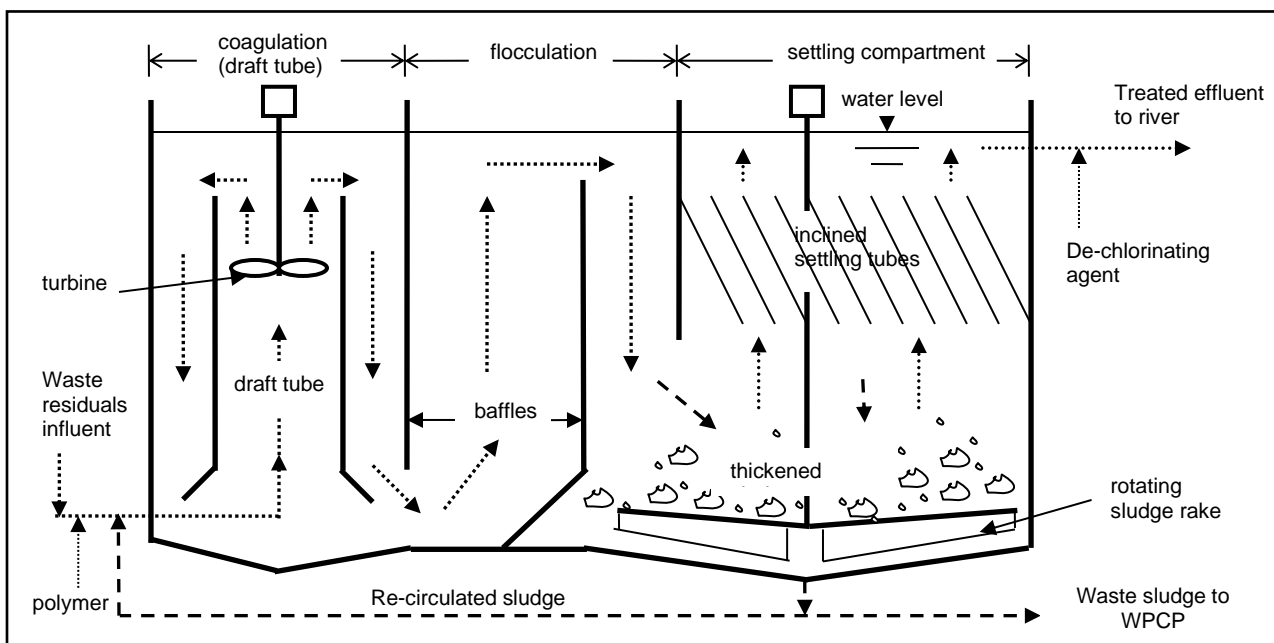

Figure 3: A.L. Dafoe Water Treatment Plant Waste Residuals Treatment Process Schematic

### Origins and Types of Contaminants

As water travels over the surface of the land or through the ground, it dissolves naturally occurring minerals and can pick up foreign substances resulting from the animals or from human activity.

The types of contaminants that may be present in source water include:

- Microbiological contaminants, such as pathogens, may come from septic systems, livestock, sewage treatment plants and/or wildlife. Microbiological quality is the most important component of drinking water quality because of its ability to cause acute illness in consumers.
- Inorganic contaminants, such as salts and metals, which can be naturally occurring or result from storm water runoff, industrial or domestic wastewater discharges, oil and gas production, mining, or farming.
- Organic contaminants can be naturally occurring, but most organic compounds of concern are man-made. Pesticides and herbicides are included in this group and may originate from a variety of sources such as agriculture, urban storm water runoff, and/or septic systems.

### ***Multiple Barriers to Microbiological Pathogens***

Potentially pathogenic (disease causing) organisms are removed from the raw water source by the following processes:

- pre-chlorination
- coagulation / flocculation / sedimentation
- filtration
- post-chlorination
- distribution system chlorine residual

### ***Laboratory Testing***

Ontario Regulation 170/03 and the Municipal Drinking Water License issued for the drinking water facility, dictate the sampling and monitoring requirements for the Napanee Drinking Water System. Water quality is tested routinely throughout the treatment process and at the extremities of the distribution system. Testing for any parameters listed as Schedules 1, 2, and 3 of Ontario Regulation 169/03 are conducted at a certified contract laboratory as required by legislation. Certified laboratories must report all drinking water test results directly to the Ministry of the Environment, Conservation and Parks and to the Town of Greater Napanee, Infrastructure Services Department.

### ***Alarms and Staffing***

The A. L. Dafoe Water Treatment Plant is typically staffed 8 hours per day, 5 days per week. On weekends and holidays, staff visit the facility to conduct routine rounds and testing. During off-hours, process irregularities or building security breaches are detected by the plant alarm system and relayed to an on-call operator.

---

## **2 Reporting of Adverse Water and Other Deficiencies**

There were no incidents of adverse water quality in the A.L. Dafoe (Napanee) Drinking Water System observed or reported during 2023.

All samples collected and tested in accordance with O.Reg.170/03 met the requirements of the Ontario Drinking Water Quality Standards. Disinfection of treated water was maintained consistently as prescribed in the MECP publication, *Procedure for Disinfecting Drinking Water in Ontario*. No corrective actions, as detailed in O.Reg.170/03, Schedule 17, were required.

Water quality data and disinfectant residuals are provided in summary tables throughout Section 3 of this report.

### 3 Flow Measurement and Analytical Testing

#### *Raw and Treated Water Flow*

Water supply to the Town of Napanee originates from either Lake Ontario or the Napanee River. Lake Ontario is the primary source while the alternate source (Napanee River) is reserved for emergency circumstances if transmission from the Lake were interrupted for an extended period. Permission to draw raw water from those sources is authorized by a Permit to Take Water issued by the Ministry of the Environment, Conservation and Parks. The current permit is valid until October 2024 and allows a maximum taking of 12,000m<sup>3</sup>/d. The Permit to Take Water was not exceeded on any day in 2023. Flow meter accuracy is checked and verified annually by a certified technician.

Raw and treated water data collected during 2023 are presented in Table 1. During 2023, all raw water treated at the A.L. Dafoe Water Treatment Plant was pumped from the Lake Ontario source. The average and maximum day raw water flows were 5,531 m<sup>3</sup>/d and 10,182 m<sup>3</sup>/d respectively.

**Table 1: Summary of raw and treated water flow for 2023**

Month	Raw Water Flow (m <sup>3</sup> /day)				Total Raw Water Flow (m <sup>3</sup> )	Treated Water Flow (m <sup>3</sup> /day)				Total Treated Water Flow (m <sup>3</sup> )
	Min	Max	Max Inst.	Avg.		Min	Max	Max Inst.	Avg.	
January	4754	5911	7.2	5385	167152	4783	6378	7632	5678	176295
February	4232	6789	7.2	5853	163549	5277	6748	7728	6135	171582
March	4280	6569	7.2	5475	169255	5148	6566	7776	5802	179937
April	3765	6263	7.2	5787	173373	2603	6724	9192	5944	178485
May	5261	6250	7.2	5787	179747	4927	6634	7800	6062	189564
June	4860	6598	7.2	5891	176480	5220	7254	8280	6245	187315
July	4254	7688	7.2	5589	170608	5048	6790	7776	5962	184732
August	3972	6118	7.2	4871	151055	4967	6878	8040	5616	173960
September	4231	10182	7.2	6956	208013	4949	7879	9576	5839	174511
October	1623	6036	7.2	4631	143321	4805	6133	8400	5442	169446
November	1994	7779	7.2	5020	150699	2483	8015	9192	5552	166622
December	4428	6300	7.2	5131	158518	5204	6957	8304	5914	183469
Annual	<b>1623</b>	<b>10182</b>	<b>7.2</b>	<b>5531</b>	<b>2011770</b>	<b>2483</b>	<b>8015</b>	<b>9576</b>	<b>5849</b>	<b>2135918</b>
Limits		<b>12000</b>	<b>10.00</b>	Permit to Take Water			<b>10450</b>	Drinking Water License		

Note: The raw water max instant flow is limited by the filter effluent valves which are programmed to permit a max flow of 7.2 m<sup>3</sup>/min.

Treated water pumped from the A.L. Dafoe Water Treatment Plant to the Napanee community during 2023 averaged at 5,849 m<sup>3</sup>/d, which is approximately 14 percent more than the average day flow recorded for the previous year. Based on the 2023 average day flow, the plant is operating at approximately 56 percent of the design capacity. The maximum day flow recorded in November 2023 represents approximately 77 percent of the design capacity of 10,450 m<sup>3</sup>/d.

Trending of monthly average day treated water flows comparing data from 2020 and 2021 (Figure 4) indicates that water consumption has remained consistent.

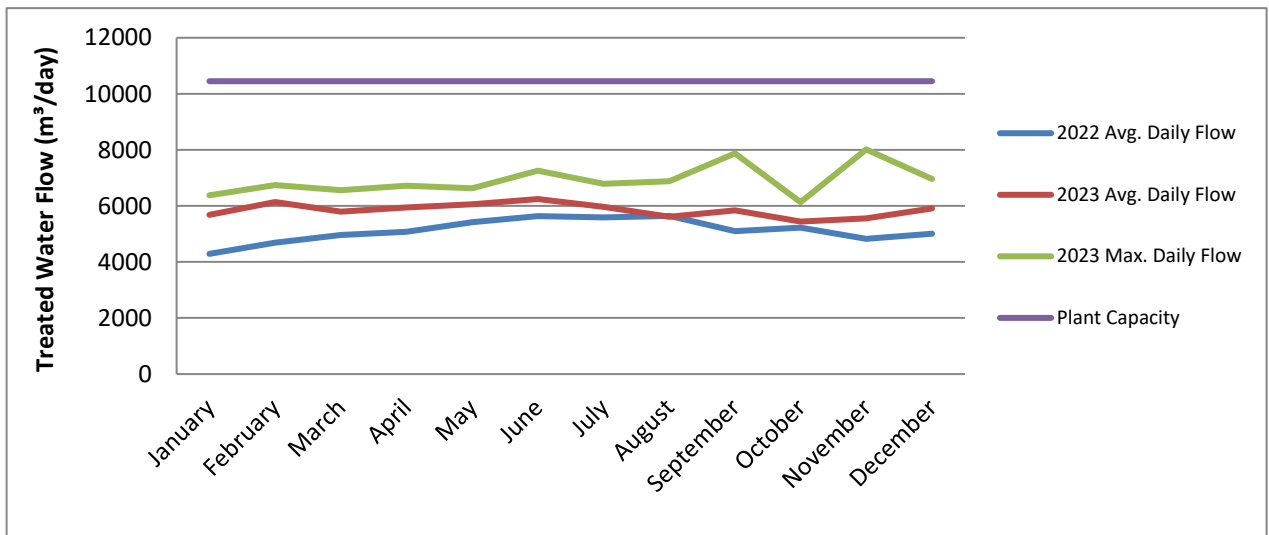

Figure 4: Monthly average daily treated water flow trends for 2022 and 2023

**Turbidity**

Turbidity, a measure of the cloudiness of water due to suspended materials, is monitored daily in the raw water entering the plant and continuously in the effluent from each of the two water treatment plant filters. Measurement of raw water turbidity is necessary to monitor any changes to the raw water that may require adjustment of the treatment process. Filtered water is monitored to verify the particulate removal efficiency of the chemically assisted filtration process.

The maximum acceptable filter effluent turbidity, according to the Ontario

Drinking Water Quality Standards (ODWQS), is 1 NTU. The treatment facility is equipped with process alarms that alert staff to abnormally high turbidity measurements well in advance of reaching that limit. In the event that the alarm set point is exceeded, the filter valves automatically close, halting the production of substandard water until the problem is addressed by operations staff.

**Table 2: Summary of turbidity in raw water and filter effluent for 2023**

Month	Raw Water Turbidity (NTU)			Filter #1 Effluent Turbidity (NTU)			Filter #2 Effluent Turbidity (NTU)		
	Min.	Max.	Avg.	Min.	Max.	Avg.	Min.	Max.	Avg.
January	0.75	10.40	2.72	0.001	0.158	0.020	0.011	0.127	0.019
February	0.78	5.17	2.12	0.012	0.136	0.024	0.014	0.150	0.031
March	0.72	2.53	1.31	0.016	0.178	0.023	0.012	0.098	0.022
April	0.72	2.37	1.07	0.019	0.212	0.032	0.017	0.256	0.033
May	0.60	1.76	0.88	0.010	0.094	0.022	0.014	0.068	0.022
June	0.58	3.97	1.28	0.014	0.115	0.020	0.016	0.150	0.023
July	0.58	1.88	0.99	0.015	0.112	0.020	0.014	0.072	0.021
August	0.44	1.10	0.73	0.014	0.119	0.018	0.012	0.070	0.016
September	0.54	1.82	0.94	0.009	0.213	0.019	0.010	0.183	0.018
October	0.52	1.63	0.85	0.003	0.097	0.018	0.011	0.091	0.014
November	0.56	3.05	1.07	0.005	0.139	0.016	0.010	0.081	0.014
December	0.46	1.06	0.66	0.010	0.185	0.018	0.011	0.097	0.025
<b>Annual</b>	<b>0.44</b>	<b>10.40</b>	<b>1.22</b>	<b>0.001</b>	<b>0.213</b>	<b>0.021</b>	<b>0.010</b>	<b>0.256</b>	<b>0.022</b>
<b>ODWQS MAC</b>	<b>-</b>	<b>-</b>	<b>-</b>	<b>-</b>	<b>1.0</b>	<b>-</b>	<b>-</b>	<b>1.0</b>	<b>-</b>

Notes: ODWQS MAC refers to the Ontario Drinking Water Quality Standards maximum acceptable concentration.

Raw water turbidity values indicate a source water of generally good clarity, averaging 1.22 NTU and ranging from 0.44 NTU to 10.40 NTU.

The annual average filtered water turbidity measured at Filters 1 and 2 were 0.021 NTU and 0.022 NTU respectively, indicating excellent treatment process performance. Filtered water turbidity did not exceed the drinking water standard at any time during 2023.

Operation of the continuous turbidity analyzers is checked by conducting periodic duplicate analysis using portable bench top instrumentation. All turbidity monitoring equipment is routinely cleaned and calibrated by staff.

### Temperature, Colour, pH, and Alkalinity

Temperature, colour, pH, and alkalinity are measured in raw and treated water each weekday and are summarized for 2023 in Table 3.

**Table 3: Summary of temperature, pH, alkalinity and colour in raw and treated water for 2023**

Month	Raw Water				Treated Water			
	Average Temp. (°C)	Average pH	Average Alkalinity (mg CaCO <sub>3</sub> /L)	Average Colour (ACU)	Average Temp. (°C)	Average pH	Average Alkalinity (mg CaCO <sub>3</sub> /L)	Average Colour (ACU)
January	4.0	8.2	64	7	4.1	7.2	58	0
February	2.6	8.1	73	10	2.8	7.2	66	0
March	2.5	8.2	90	11	3.4	7.2	81	0
April	5.1	8.2	93	13	9.4	7.3	83	0
May	9.1	8.2	92	8	11.4	7.2	83	0
June	14.6	8.4	89	6	17.7	7.3	80	0
July	19.9	8.4	85	7	23.9	7.4	77	0
August	20.8	8.1	86	6	27.0	6.8	75	0
September	20.5	7.7	82	8	24.6	6.7	74	0
October	16.9	7.6	87	8	19.7	6.6	77	0
November	11.4	7.5	92	6	15.0	6.6	81	0
December	7.5	7.6	91	6	11.2	6.6	83	0
<b>Annual Avg.</b>	<b>11.2</b>	<b>8.0</b>	<b>85</b>	<b>8</b>	<b>14.2</b>	<b>7.0</b>	<b>76</b>	<b>0.0</b>
<b>Total Range</b>	<b>2.1 - 23.3</b>	<b>7.3 - 8.9</b>	<b>50 - 109</b>	<b>2 - 24</b>	<b>1.0 - 30.0</b>	<b>6.4 - 7.6</b>	<b>48 - 97</b>	<b>0 - 2</b>
Objective	-	-	-	-	<15	6.5 - 8.5	30 - 500	5

Note: Objective refers to non-health related objectives from the ODWQS

The data shows that the raw water supply varies significantly in temperature over the course of the year. Raw water temperature ranged from 2.1°C to 23.3°C, while treated water ranged from 1.0°C to 30.0°C. Coagulants (such as alum, which is used in the A.L. Dafoe treatment process) do not act as quickly in colder water and therefore dosage adjustments may be required during winter months.

Colour develops in raw water sources from the decay of naturally occurring organic matter. The resulting colloidal and dissolved organic compounds react with coagulant chemicals and can increase dosage requirements. Colour removal is sometimes enhanced by pre-chlorination. During 2023, raw water colour



---

measurement ranged from 2 apparent colour units (ACU) to 24 ACU, averaging 8 ACU. Effective removal was achieved through the process as the maximum colour in treated water samples in 2023 was 2 ACU.

Coagulants are most effective within specific ranges of pH. Alum performs best between pH 5.8 and pH 8.5. It is important to note that alum is an acidic solution which tends to lower the alkalinity and pH of process water. Both raw and treated water pH values were relatively stable throughout the year, averaging 8.0 and 7.0 respectively.

Closely related to pH, alkalinity is a measurement of the acid buffering capacity of water. (The higher the alkalinity, the more acid that can be added before a change in pH occurs.) Several substances naturally present in raw water are measured as alkalinity, the majority of which are carbonate compounds.

Coagulants, when added to water, combine with the alkalinity to produce insoluble metal hydroxides that play an important role in forming good floc. Alum, as mentioned above, is acidic and therefore decreases alkalinity. If too much natural alkalinity is consumed neutralizing the alum, there may be insufficient alkalinity remaining for optimal floc formation. Therefore, if a noticeable drop in pH (and alkalinity) is occurring, it may be necessary to lower the coagulant dosage to conserve alkalinity, or to add alkalinity to the incoming raw water. Raw and treated water alkalinities were relatively consistent through 2023 averaging 85 mg/L and 76 mg/L, respectively. All treated water alkalinity measurements were within the ODWQS recommended operational objective range of 30 – 500 mg/L.

### ***Disinfection***

Disinfection of the water supply protects public health by ensuring the inactivation of potentially harmful micro-organisms that may have passed through the treatment process or entered the distribution system by other means. A minimum

---

free residual of 0.2 mg/L, maintained throughout the distribution system, is recommended by the *Procedure for Disinfecting Drinking Water in Ontario*. Less than 0.05 mg/L free residual is considered adverse and may pose a potential threat to public health. Additionally, the guideline requires that treated water must be mixed with the disinfectant and retained for a minimum period of time before distributing to customers. This is referred to as CT which is the product of the disinfectant concentration and the amount of time the water is exposed to the disinfectant. Research has demonstrated that CT is directly related to the rate of pathogen inactivation.

Chlorine residuals are monitored continuously in raw and treated water. The treated water residual analyzer is equipped with alarms that alert the operators to process abnormalities and will shut down the process to prevent improperly disinfected water from entering the distribution system.

Treated water free chlorine residual measured at the treatment facility averaged 1.82 mg/L in 2023, which is well above the guideline minimum value of 0.2 mg/L. It is important to note that chlorine residual typically declines in proportion to the distance from the point of application. Relatively high chlorine residuals are required leaving the plant in order to ensure that at least 0.2 mg/L is maintained throughout the distribution system. Disinfectant residuals are summarized in Tables 4, 5, and 6.

Chlorine residual measurements are conducted using portable bench top instrumentation on distribution system samples and periodically on plant treated water to provide verification of the continuous analyzer values. Calibrations of measurement instruments are routinely conducted by staff.

### ***Bacteriological Testing***

Bacteriological testing verifies the effectiveness of the disinfection process by monitoring the presence of indicator organisms in the water supply. The indicator

tests include total coliforms (TC), *Escherichia coliforms* (*E. coli*), and heterotrophic plate count (HPC). The confirmed presence of any TC or *E. coli* in the water supply indicates insufficient disinfection and an increased risk to public health.

Bacteriological testing is conducted on samples collected each week from the raw water source, the treatment plant, and at several remote locations within the distribution system. A total of 52 raw water samples were taken from Lake Ontario for bacteriological testing in 2023. A total of 364 water samples were collected from the treatment plant and distribution system for bacteriological testing in 2023. All test results met the requirements of the Ontario Drinking Water Quality Standards. Tables 4, 5 and 6 summarize results of raw, treated and distribution system bacteriological testing.

**Table 4: Summary of treated water disinfection and bacteriological results from 2023**

Month	Treated Water								
	Free Chlorine Residual (mg/L)			Total Chlorine Residual (mg/L)			Total Coliforms (org./100mL)	E.Coli (org./100mL)	HPC (org./100mL)
	Min.	Max.	Avg.	Min.	Max.	Avg.			
January	1.68	1.88	1.81	1.72	2.14	1.97	0	0	<10
February	1.54	1.83	1.72	1.62	2.02	1.86	0	0	<10
March	1.38	1.82	1.75	1.85	2.28	2.01	0	0	<10 - 10
April	1.46	2.11	1.88	1.81	2.20	2.02	0	0	<10
May	1.51	1.93	1.80	1.68	2.14	1.93	0	0	<10 - 20
June	1.40	1.72	1.63	1.67	1.96	1.81	0	0	<10 - 20
July	1.46	1.81	1.66	1.69	1.96	1.83	0	0	<10 - 10
August	1.35	1.94	1.81	1.64	1.98	1.82	0	0	<10 - 30
September	1.49	2.10	1.86	1.64	2.18	1.87	0	0	<10 - 20
October	1.38	2.20	1.92	1.77	1.98	1.88	0	0	<10 - 10
November	1.90	2.15	2.06	1.79	2.28	2.05	0	0	<10
December	1.78	2.10	1.93	1.77	2.18	2.04	0	0	<10
# of samples	continuous**			249	249	249	52	52	52
Annual	1.35	2.20	1.82	1.62	2.28	1.92	-	-	-
Range	-	-	-	-	-	-	n/a	n/a	<10 - 30
ODWQS	-	-	0.2	-	-	-	<1	<1	<200

\*\* In addition to continuous monitoring, treated water free chlorine residuals are measured daily through in house analysis.  
Note: Bacteriological results are presented as the range observed for each month

Table 5: Summary of distribution water disinfection and bacteriological results from 2023

Month	Distribution Water								
	Distribution Continuous Free Cl <sub>2</sub> (mg/L)			Distribution Grab Sample Free Cl <sub>2</sub> (mg/L)			Total Coliforms (org./100mL)	E.Coli (org./100mL)	HPC (org./100mL)
	Min.	Max.	Avg.	Min.	Max.	Avg.			
January	1.12	2.04	1.85	0.92	1.62	1.33	0	0	<10 - 20
February	1.48	2.05	1.83	0.96	1.58	1.32	0	0	<10
March	1.75	2.07	1.92	1.05	1.71	1.40	0	0	<10 - 30
April	1.31	2.06	1.75	0.92	1.69	1.36	0	0	<10 - 20
May	1.32	1.85	1.72	1.01	1.68	1.35	0	0	<10 - 20
June	1.26	1.72	1.61	0.72	1.50	1.20	0	0	<10 - 20
July	1.24	1.93	1.60	0.61	1.53	1.10	0	0	<10 - 270
August	1.48	2.02	1.78	0.58	1.79	1.18	0	0	<10 - 10
September	1.14	2.22	1.85	0.61	1.65	1.11	0	0	<10 - 30
October	1.56	2.10	1.91	0.69	1.58	1.21	0	0	<10 - 20
November	1.77	2.11	2.00	0.78	1.87	1.46	0	0	<10 - 10
December	1.62	1.97	1.85	0.68	1.92	1.41	0	0	<10 - 10
# of samples	continuous			312			312	312	312
Annual	1.12	2.22	1.81	0.58	1.92	1.29	-	-	-
ODWQS							0	0	<10 - 270

Note: Bacteriological results are presented as the range observed for each month.

Table 6: Summary of raw water disinfection and bacteriological results from 2023

Month	Raw Water								
	Free Chlorine Residual (mg/L)			Total Chlorine Residual (mg/L)			Total Coliforms (org./100mL)	E. Coli (org./100mL)	HPC (org./100mL)
	Min.	Max.	Avg.	Min.	Max.	Avg.			
January	0.20	0.72	0.40	0.04	1.22	0.61	0 - 130	0	10
February	0.06	0.93	0.46	0.00	1.84	0.71	0	0	40 - 140
March	0.16	1.52	0.81	0.01	2.89	1.09	0	0	<10 - 10
April	0.06	0.79	0.38	0.02	0.83	0.39	0 - 42	0	10 - >2000
May	0.02	1.22	0.54	0.00	1.11	0.61	0	0	<10 - >2000
June	0.20	1.01	0.64	0.02	1.62	0.85	0	0	80 - 310
July	0.04	1.00	0.56	0.00	1.40	0.63	0 - 5	0	10 - 500
August	0.02	0.70	0.31	0.00	1.12	0.50	0 - 16	0 - 3	<10 - 300
September	0.00	0.68	0.26	0.00	2.26	0.51	0	0	70 - 370
October	0.06	0.54	0.29	0.00	1.22	0.25	0 - 55	0	<10 - >2000
November	0.03	0.77	0.60	0.04	2.71	0.73	0	0	<10 - >2000
December	0.48	1.08	0.77	0.23	2.07	0.93	0 - 109	0 - 2	<10 - >2000
# of samples	249	249	249	Continuous			52	52	52
Annual	0.00	1.52	0.50	0.00	2.89	0.65	0 - 130	0 - 3	<10 - >2000

---

### **Process Chemical Addition**

Two chemicals, aluminum sulphate (alum) and sodium hypochlorite are essential additives to the A.L. Dafoe water treatment process. Alum is a commonly used water treatment coagulant that is necessary for the effective operation of the flocculation and sedimentation processes. Average monthly alum dosages at the A. L. Dafoe Water Treatment Plant remained consistent throughout 2023, ranging from a low of 29.2 mg/L to a maximum of 42.8 mg/L. The total volume of alum used during 2023 decreased by 21 percent when compared to 2022.

Aluminum, a component of alum, is sometimes observed in elevated concentrations in treated water when high dosages of alum are applied. Although not identified in the ODWQS as a health risk, high aluminum residual in the distribution system may cause scaling on pipes, interfere with certain industrial processes, or form floc particles within the distribution system. The aluminum concentration was tested in samples of treated water on 249 days in 2023. All results were below the ODWQS operational guideline limit of 0.1 mg/L. The maximum aluminum concentration observed during 2023 was 0.090 mg/L while the average was 0.019 mg/L.

Sodium hypochlorite is added as a disinfectant to ensure that the treated water is free of active pathogens. Variations in chlorine dosages are typical throughout any given year. Dosage adjustments are made necessary by changes in water temperature, pH, flow rates, and distribution system residuals. Overall chlorine consumption is typically higher during summer months due to the seasonal increase in water demand. The volume of disinfectant used in 2023 was just over 12% more than that used in 2022, which amounts to 9,292 litres.

**Table 7: Summary of process chemical usage and dosage for 2023**

Month	Alum			Sodium Hypochlorite			
	Monthly Usage (L)	Average Dosage (mg/L)	Treated Water Aluminum Residual (mg/L)	Pre-Cl <sub>2</sub> Usage (L)	Pre-Cl <sub>2</sub> Dosage (mg/L)	Post-Cl <sub>2</sub> Usage (L)	Post-Cl <sub>2</sub> Dosage (mg/L)
January	9983	32.3	0.012	2638	2.21	3292	2.62
February	9832	32.6	0.013	3187	2.37	3148	2.57
March	9796	31.1	0.017	3851	2.72	3312	2.59
April	11524	36.7	0.010	4869	3.47	3408	2.67
May	11973	35.9	0.014	4843	3.23	3513	2.60
June	11292	34.1	0.018	4874	3.28	3389	2.54
July	11029	34.1	0.030	4352	2.99	3713	2.82
August	11395	37.3	0.032	3125	2.28	3535	2.85
September	11778	38.4	0.030	3196	2.34	3540	2.84
October	11791	39.6	0.018	2696	2.02	3431	2.84
November	10861	37.4	0.019	2417	1.85	3132	2.63
December	10603	33.1	0.010	2662	1.85	3376	2.58
<b>Annual Average</b>	<b>10988</b>	<b>35.2</b>	<b>0.019</b>	<b>3559</b>	<b>2.55</b>	<b>3399</b>	<b>2.68</b>
<b>Annual Total</b>	<b>131857</b>	<b>-</b>	<b>-</b>	<b>42710</b>	<b>-</b>	<b>40789</b>	<b>-</b>

### **Chemical Testing**

Analyses of nearly 70 additional organic and inorganic parameters in the treated water are required at various frequencies. The majority of those substances, listed as Schedules 23 and 24 in Ontario Regulation 170/03 must be tested at least annually. Testing for nitrite, nitrate, trihalomethane, and haloacetic acid compounds is required quarterly, while sodium and fluoride must be tested once every 5 years.

The results of those analyses are summarized in Tables 8, 9, 10, 11 and 12. Concentrations of the majority of the substances were lower than the analytical method detection limits (either non-existent or in trace levels too low to quantify), while the remaining substances measured below the ODWQS limits.

**Table 8: Results of samples collected on January 10, 2023 to meet testing requirements for parameters listed in Schedule 23 of O.Reg. 170/03**

Parameter	ODWQS Limit (mg/L)	Concentration (mg/L)
Antimony	0.006	0.0001
Arsenic	0.025	0.0002
Barium	1	0.022
Boron	5	0.016
Cadmium	0.005	<0.00001
Chromium	0.05	<0.002
Mercury	0.001	<0.00002
Selenium	0.01	<0.001
Uranium	0.1	0.00007

**Table 9: Results of samples collected on January 10, 2023 and February 07, 2023 to meet testing requirements for parameters listed in Schedule 24 or O.Reg. 170/03**

Parameter	ODWQS		Concentration (µg/L)
	Limit (µg/L)	Type	
Alachlor	5	IMAC	<0.3
Atrazine + Metabolites	5	MAC	<0.5
Azinphos-methyl	20	MAC	<1
Benzene	5	MAC	<0.5
Benzo(a)pyrene	0.01	IMAC	<0.006
Bromoxynil	5	IMAC	<0.5
Carbaryl	90	IMAC	<3
Carbofuran	90	MAC	<1
Carbon tetrachloride	5	MAC	<0.2
Chlorpyrifos	90	MAC	<0.5
Diazinon	20	IMAC	<1
Dicamba	120	MAC	<1
1,2-dichlorobenzene	200	MAC, AO: 3	<0.5
1,4-dichlorobenzene	5	MAC, AO: 1	<0.5
1,2-dichloroethane	5	MAC	<0.5
1,1-dichloroethylene	14	MAC	<0.5
Dichloromethane	50	MAC	<5
2,4-dichlorophenol	900	MAC, AO:0.3	<0.2
2,4-dichlorophenoxy acetic acid	100	MAC	<1
Diclofop-methyl	9	MAC	<0.9
Dimethoate	20	IMAC	<1
Diquat	70	MAC	<5
Diuron	150	MAC	<5
Glyphosate	280	MAC	<25
Malathion	190	MAC	<5
2-Methyl-4-chlorophenoxyacetic acid*	100	MAC	<10

Table 9: (continued)

Parameter	ODWQS		Concentration (µg/L)
	Limit (µg/L)	Type	
Metolachlor	50	IMAC	<3
Metribuzin	5	MAC	<3
Monochlorobenzene	80	MAC, AO: 30	<0.5
Paraquat	10	IMAC	<1
Pentachlorophenol	60	MAC, AO: 30	<0.2
Phorate	2	IMAC	<0.3
Picloram	190	IMAC	<5
Polychlorinated Biphenyls	3	IMAC	<0.05
Prometryne	1	IMAC	<0.1
Simazine	10	IMAC	<0.5
Terbufos	1	IMAC	<0.5
Tetrachloroethylene	30	MAC	<0.5
2,3,4,6-Tetrachlorophenol	100	MAC, AO: 1	<0.2
Triallate	230	MAC	<10
Trichloroethylene	50	MAC	<0.5
2,4,6-Trichlorophenol	5	MAC, AO: 2	<0.2
Trifluralin	45	IMAC	<0.5
Vinyl Chloride	2	MAC	<0.2

Table 10: Results of samples collected on January 07, 2020 to meet testing requirements for Fluoride and Sodium in O. Reg. 170/03

Parameter	ODWQS Limit (mg/L)	Concentration (mg/L)
Fluoride	1.5	0.1
Sodium	20*	17.3

\*aesthetic objective is 200 mg/L, but the Medical Officer of Health must be notified when the sodium concentration exceeds 20 mg/L.

Table 11: Results of samples collected and analyzed to meet quarterly testing requirements under Schedule 15 of O.Reg. 170/03

Parameter	Units	ODWQS Limit	Sample Collected				Annual Average
			10-Jan-23	12-Apr-23	04-Jul-23	03-Oct-23	
Nitrate	mg/L	10	0.3	0.4	0.2	0.1	
Nitrite	mg/L	1	<0.2	<0.05	<0.05	<0.05	
Chloroform	µg/L	-	27	96	83	29	
Bromodichloromethane	µg/L	-	10	11	16	10	
Dibromochloromethane	µg/L	-	3	2	3	3	
Bromoform	µg/L	-	5	5	5	5	
Total THMs	µg/L	100	40	108	101	42	72.8



**Table 12: Results of samples collected and analyzed to meet quarterly testing requirements under Schedule 13 of O.Reg. 170/03**

Parameter	Units	ODWQS Limit	Sample Collected				Annual Average
			10-Jan-23	12-Apr-23	04-Jul-23	03-Oct-23	
Haloacetic Acid	µg/L	80	14.7	75.2	27.8	6.6	31.1
Chloroacetic Acid	µg/L	-	4.7	4.7	4.7	4.7	
Bromoacetic Acid	µg/L	-	2.9	2.9	2.9	2.9	
Dichloroacetic Acid	µg/L	-	5.9	22.1	13.2	6.6	
Dibromoacetic Acid	µg/L	-	2	2	2	2	
Trichloroacetic Acid	µg/L	-	8.8	53.1	14.6	5.3	

### **Lead Testing**

The A.L. Dafoe (Napanee) Drinking Water System qualified for reduced sampling requirements, as measured lead concentrations observed in samples collected from residential plumbing do not pose a risk to public health based on current standards. In 2021, the municipal lead sampling program continued with distribution system testing conducted over two intervals; the first between December 15, 2020 and April 15, 2021 representing cold water conditions, and the second between June 15, 2021 and October 15, 2021 when water temperature is warmer. During each round, staff were required to sample 3 distribution system locations. All of the required samples were collected, and all were below the Ontario Drinking Water Quality Standards limit for lead. Lead concentrations observed in all of the samples collected in 2021 were well below the regulatory limit. Napanee continues to be exempt from any further residential plumbing sampling unless future distribution testing indicates a change in water chemistry or elevated lead concentrations. There were no requirements to sample for lead in 2023, but the lead sampling program will continue again in 2024.

**Table 13: Results of samples collected and analyzed to meet the testing requirements under Schedule 15.1 of O.Reg. 170/03**

Sample Location	15-Jan-21			06-Jul-21		
	Lead (mg/L)	Alkalinity (mg/L)	pH	Lead (mg/L)	Alkalinity (mg/L)	pH
Sample Hydrant: Hwy 2 W	0.00007	78	7.38	0.00017	80	7.21
Sample Hydrant: Hwy 41	0.00007	76	7.28	0.00019	79	7.19
Sample Hydrant: Palace Rd	0.00011	77	7.36	0.00016	77	7.06
<b>ODWQS Limit / Objective</b>	0.001*	30 - 500	6.5 - 8.5	0.001*	30 - 500	6.5 - 8.5

\*Indicates objective for reduced sampling

### ***Waste Residuals Treatment Process***

The waste residuals treatment process is designed to thicken the waste generated from the water treatment process which includes alum sludge from the sedimentation process as well as filter backwash water. The thickened waste is discharged to the municipal sewer for further treatment at the Water Pollution Control Plant, while the treated supernatant (effluent) from the process flows to the Napanee River.

Suspended solids measured in the effluent from the process are not to exceed an annual average of 25 mg/L. Although composite sampling of the effluent is required once per week, the process is also equipped with continuous suspended solids monitoring instrumentation which will automatically shut down the process if the effluent limit is approached. This safeguard protects the Napanee River from accidental discharges of non-compliant effluent.

The residuals treatment process performed well while in operation in 2023 as effluent solids remained below the regulated limit. The process was out of service for the later part of 2023, and during that time all process waste was discharged to the sanitary sewer for further treatment. While the residuals treatment process was in service, the annual average effluent total suspended solids concentration

was 5.02 mg/L.

Effluent from the process is de-chlorinated if necessary, by the addition of sodium bisulphite. Chlorine was not detected in any of the effluent samples discharged to the Napanee River during 2023.

**Table 14: Summary of results from waste residuals treatment process monitoring**

Sample Type	Number of Samples	Total Suspended Solids (mg/L)			Municipal Drinking Water License Max. (mg/L)
		Min.	Max.	Avg.	
Thickener Effluent	26	1	14	5.02	25**
Thickener Sludge	26	14	862	150	

\*\* Municipal Drinking Water License speaks to an annual average

---

#### **4 System Maintenance and Improvements**

Maintenance and improvements at the Napanee facilities during 2023 included the following:

- Distribution system fire hydrants were inspected, lubricated, and flow tested. The hydrant program serves as a preventive maintenance measure that identifies repair requirements and ensures reliability for community fire protection. Flushing also rids the distribution piping of accumulated sediments.
- The Town of Greater Napanee continued to work closely with Quinte Conservation and Cataraqui Region Conservation Authority regarding the approved Source Water Protection Plans and Education and Outreach programs.
- Necessary watermain replacement and upgrades were completed on a portion of East Street. The existing watermain was replaced with a more durable polyvinyl chloride (PVC) watermain. This project also included the replacement of water services and curb stops on municipal properties.
- 186 residential water meters were replaced within the distribution system as part of the 20-year replacement program. This program enhances accuracy in water usage monitoring and aids in eliminating water loss within the distribution system.
- The liner was replaced within the larger raw water reservoir, which allows for significant redundancy to our raw water supply.